

CHAPTER ONE

Constructing the Near Space Capsule Airframe

"Let us create vessels and sails adjusted to the heavenly ether, for there will be plenty of people unafraid of the empty wastes"
- by Kepler, in a letter to Galileo

Chapter Objectives

1.0	Two Simple Airframes	1
2.0	Building the NearSys Airframe.....	12
3.0	Covering Airframes with Multi-Layer Insulation (MLI)	18
4.0	A Simple Landing Bag	20
5.0	The Abrasion Jacket.....	21
6.0	The Module Hatch.....	28
7.0	Making Link Lines	32
	Good to Know: A Short Introduction To Thermodynamics	34
	Near Space Humor: Ten Signs that your First Near Space Mission is Not Going Well... ..	35

1.0 Two Simple Airframes

In the first section of this chapter I'll describe two quick-to-make airframes that near space groups have used very successfully. One of these airframes, along with a simple tracker and parachute, quickly gets your first mission airborne. These simple airframes are ideal for getting a program started while you construct more complex airframes and flight computers.



Lunch Bag Airframe – Airframes can be built from anything that is lightweight and provides some insulation, including reusable lunch bags.

1.1. A Fast and Simple Airframe – The Lunch Bag

What is the fastest way to get into near space? Probably by using an airframe that is available from your local department store. A good example of a quickly constructed airframe is Mark Conner's (N9XTN) first near spacecraft. Mark constructed his first airframe from a reusable lunch bag. These lunch bags are insulated and soft-sided. The lunch bag's only closure is a zipper which wraps three quarters of the way around the bag. This airframe design provides both cushioning and insulation for the interior avionics. To maintain the airframe's dimensions, cut a block of foam rubber to fit the interior shape of the lunch bag. Either cut pockets into the foam rubber block to immobilize the avionics inside the airframe, or tie the avionics to a corrugated plastic pallet. The lunch bag's handle strap secures the recovery parachute to the airframe. However, the recovery parachute's single attachment point makes this airframe twist more frequently. This makes the reusable lunch bag a less stable camera platform, which is most noticeable during the early descent of the near spacecraft after balloon burst.

It can be difficult to integrate external experiments into this style of airframe, as the soft-sided bag provides little mounting capability. However, experiments designed to mount either inside the airframe or to dangle freely outside the airframe are easily integrated. To keep from having to cut a foam rubber block for each new mission, cut an extra open pocket into the original foam rubber block. Place the internally mounted experiment into this pocket and fill the remaining open space with Styrofoam^A peanuts. A cosmic ray experiment consisting of an internally mounted Geiger counter or an environmental sounder consisting of externally mounted temperature, pressure, and relative humidity sensors are examples of interesting experiments you can carry on this style of airframe. Exercise caution when closing the bag's zipper on cables extending from the interior of the bag.

Cameras are a bit more difficult to fly in this style of airframe but can still be flown. In this case it is best to mount the camera inside the airframe and to cut a hole into the wall of the airframe for the camera lens. Sew the raw edges of the cut hole to keep the fabric of the lunch bag from fraying and the bag's insulation from falling out. Keep it simple by using a camera with an automatic timer. Some of these cameras are available with delays of up to ten minutes. How about sending a camcorder into near space? The camcorder takes up more space than a camera, so a change needs to be made. There's no reason a second lunch bag airframe can't be attached to the original lunch bag airframe by strong nylon lines or Spectra^B kite line (the preferred line). The camcorder is then placed

into its own lunch bag. Use a cut foam rubber block to securely mount the camcorder into its airframe. If you send a camera or camcorder into near space, make sure you remember to open the camera lens and start the camcorder before launch.

1.1.1. A Fast and Simple Antenna

The best antenna for this style of airframe is one designed to dangle freely. As an example, Mark's first near space antenna is a J-pole made from ladder line. One end of the ladder line connects to the BNC-type antenna cable connector of the Handi-Talkie (HT) inside the airframe. The ladder line then passes outside the airframe through the slightly unzipped lunch bag and hangs freely below the near spacecraft. Telemetry from Mark's near spacecraft is very good with this antenna. Ground stations hundreds of miles away regularly receive telemetry from Mark's near spacecraft. A second type of antenna is a soft dipole, with the top element tied to a parachute shroud line. The bottom element of the dipole antenna is left to dangle below the airframe. See Chapter Three, Section Three for information on making these antennas.

1.1.2. A Fast and Simple Tracker as Avionics

Individuals looking to get into near space in a jiffy can use the above airframe design coupled with a simple automatic position reporting system (APRS) tracker as avionics. Three examples trackers are: 1) the Kenwood D-7A data radio and global positioning system (GPS) receiver; 2) the Tiny Trak II with a Garmin GPS receiver and Alinco DJ-S11; and 3) the MIM with a Garmin GPS receiver and an Alinco DJ-S11 HT. In the case of the D-7A and GPS receiver, mount the avionics inside pockets cut into the foam rubber insert. In the case of the Tiny Trak II or MIM, mount the GPS and HT inside a pocket cut into the foam rubber insert and zip tie the Tiny Trak or MIM PCB to a sheet of corrugated plastic placed in the bottom of the airframe. For information on building this simple tracker or flight computer, read Chapter Two, Sections Five or Six. Of course an APRS tracker limits the science your near spacecraft can perform. More can be done if you replace the APRS tracker with a flight computer as described in chapter three.



Interior of Lunch Bag Airframe
 -The interior of Jeff Melanson's (K7INN) lunch bag airframe. Inside, the GPS, TNC, HT, and a thermochron are cushioned with foam rubber.

This design, a reusable lunch bag, dangling J-pole antenna, and simple APRS tracker, may be just the thing to introduce a radio club to near space activities. This may be especially true when the club is

hesitant to spend the time and money to create a more advanced program. Some near space programs with more elaborate avionics use this design as a backup tracker on near space flights.

1.2. A Slightly More Complex Airframe – The Bait Bucket

For an airframe with more flexibility, you might try Bill All's (N0KKM) first design. Bill's first near spacecraft was the popular Styrofoam cooler or bait bucket with a homemade abrasion jacket.

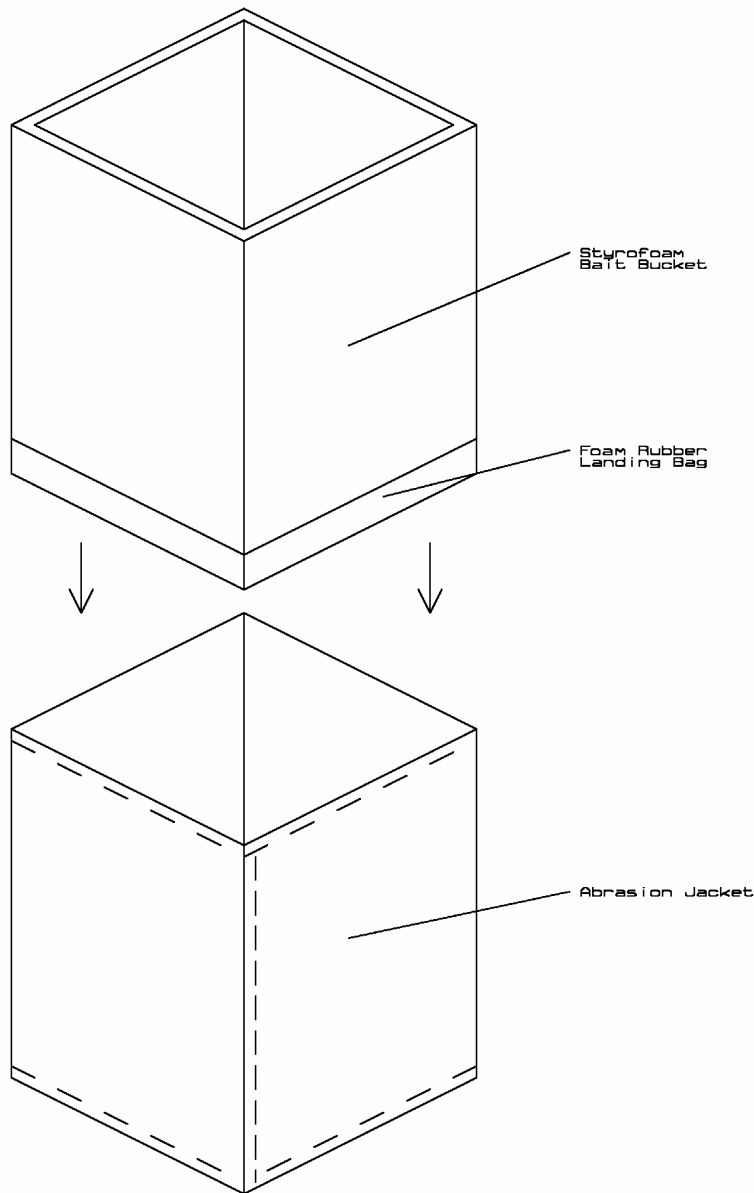

Bait Bucket with Abrasion Jacket – Jacket patterns to follow.

Its foam walls provide both insulation and a solid surface for mounting external experiments. It is difficult to cut experiment ports into a bait bucket. However, small experiments can be mounted to the antenna boom of the bait bucket airframe. After making the abrasion jacket for the bait bucket airframe, mount the antenna on top of the bucket lid. See Chapter Five, Section Three for directions on making the antenna boom. Since the airframe always has an HT inside of it, the coax to the HT's external antenna should be permanently mounted into the airframe. Cut a small hole in the foam wall

of the cooler or bucket lid and pass the coax through it. Seal the hole with caulking compound or a chunk of cut foam. As for a recommended coax to use, read Chapter Four, Section Three on making antennas with lengths of pre-crimped coax.

1.2.1. Mounting Avionics and Internal Experiments

One method of mounting avionics is to cut a sheet of corrugated plastic material, such as Coroplast^C, to fit the bottom of the airframe, and simply zip-tie the avionics to this “pallet”. If pockets on the pallet are needed to hold components like the HT, they can be built into this avionics pallet by hot gluing Styrofoam blocks to the corrugated plastic.

Internal experiments placed inside the airframe will bounce around during a mission, causing endless mischief. To prevent this from occurring, fill the remaining internal space of the airframe with foam peanuts. However, be sure you DO NOT use biodegradable peanuts! These peanuts dissolve in water. If there is any condensation inside your airframe during a mission, you will end up with a thick starchy muck coating your avionics and experiments. Personally I believe the S-shaped peanuts are better than the shell-shaped peanuts, as the S-shaped peanuts occupy more volume and can’t pack as tightly as the shells.

1.2.2. Attaching the Recovery System

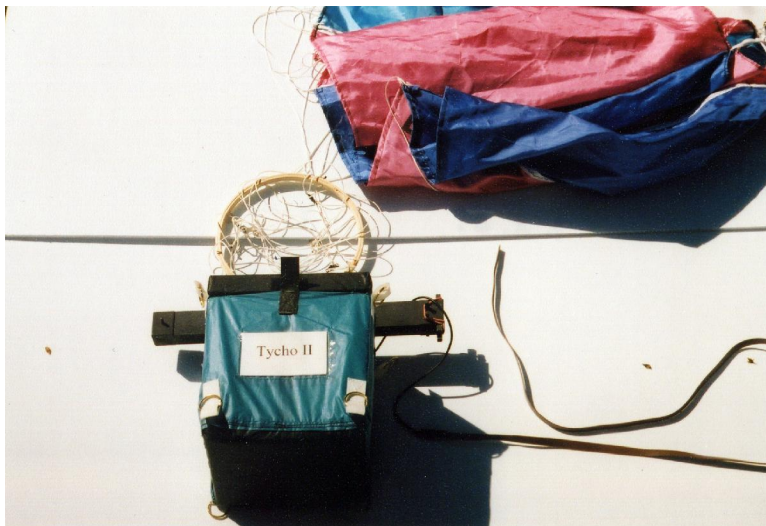

Bait box Capsule With Parachute Attached to Jacket -
A bait bucket modified into a near spacecraft module. This one operated as a backup tracker for a mission reaching 98,000 feet.

In this style of airframe, unlike a reusable lunch bag, there is no handle for attaching the recovery system (the parachute’s shroud lines). If you mount the parachute’s shroud lines to the airframe through holes drilled into the Styrofoam, the lines will rip up the airframe once the balloon bursts. When this occurs the ground slows the near spacecraft’s descent speed, instead of a parachute (this is known as lithobraking, as opposed to aerobraking, and is frowned upon by the FAA). Obviously, this recovery method is very hard on hardware and property. So let me recommend a better method for attaching recovery systems to Styrofoam cooler and bait bucket style airframes.

This method uses a fabric bag (a jacket) to hold the airframe. Attachment points for recovery systems and other modules are sewn securely into the jacket. The airframe is not required to withstand the stress of the recovery system’s shroud lines. You need the following materials to make the airframe jacket:

- Two yards of ripstop nylon^{D*} (also called spinnaker cloth)

- One yard of $\frac{3}{4}$ " Dacron^E tape*
- Eight 1" split key rings
- One yard Velcro^F
- One yard of thin clear vinyl

* Purchase these materials from a kite store, such as Into The Wind (www.intothewind.com)

Jacket Pattern, Marking and Cutting Ripstop

If you're good at visualizing geometry, you can measure the dimensions of your airframe and cut the ripstop to size. The pattern for a seven-inch cube bait bucket is presented in this section. There are three pieces in the pattern: the bottom jacket, the side jacket, and the hatch jacket. The side jacket forms a square tube that wraps around the bait bucket. The bottom jacket is sewn to the bottom of the side jacket after Dacron loops are attached to the side jacket. The hatch jacket fabric is wrapped tightly around the Styrofoam lid of the bait bucket and hand-stitched in place.

The Bait Bucket

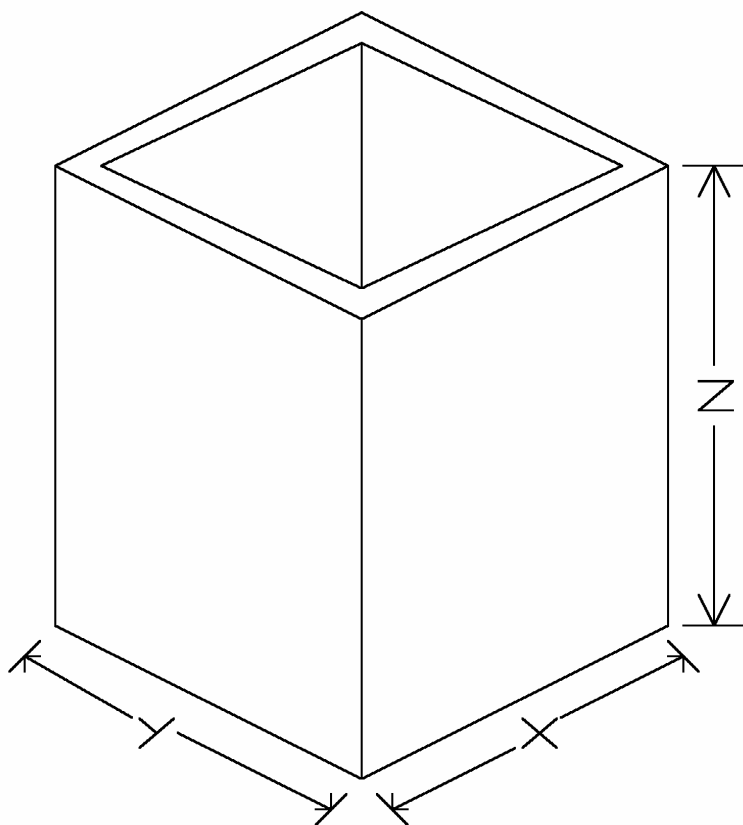

Bait Bucket Dimensions – For my bait bucket, $x=7"$, $y=7"$, $z=6"$, however, I added 1" of foam rubber to the bottom to make $z=7"$.

If you're unsure of your abilities to make a pattern, then cut experimental patterns with butcher paper. Don't forget to add at least $1\frac{1}{2}$ -inch seam allowances to the dimensions of the bucket when drafting your pattern for the side and bottom jackets. For the hatch jacket, you will need a piece large enough to tightly wrap the lid gift-wrap style. Never sew raw edges together without first doubling over the seam $\frac{1}{4}$ " at least once and preferably twice. When working with nylon fabrics, it's best to cut the fabric with a hot soldering iron. Some soldering irons come with cutting tips for this purpose. The

hot cutter melts the raw edge of the fabric, preventing the raw edge from fraying. When possible, use a wooden ruler with a thin metal edge to guide the soldering iron. The metal on the ruler conducts heat away from the hot soldering tip. Form creases in the ripstop by running a finger nail over the folded fabric. If you decide to use an iron in place of a finger nail, use a low heat setting as high temperature settings make the fabric curl.



Cutting Tip - The cutting tip looks like a small ball on the end of the soldering gun's tip.

Draw the pattern onto the ripstop using a colored pencil contrasting with the color of the fabric. Cut out the three pieces of ripstop for the jacket. If you cut the fabric with scissors instead of a soldering iron, fold over the raw edges of the seam allowances about 1/4" and stitch down, with a zig-zag stitch if you can. Creasing the fold with your fingernail before stitching will make the sewing easier. Be sure to backstitch at the beginning and ending of each seam. This step will prevent the cut edges from unraveling as you continue your work.

Side Jacket

First, select one long edge to be the top edge of the jacket. Turn this edge under by another 1/2", crease, and stitch down. Next, sew the opposite end of the side jacket together to form a tube. Wrap the fabric around the bucket wrong side out, then pin the ends together for a custom fit. Remove the fabric from the bucket and sew the side seam, turn it right side out, and test the fit again. If it fits too loosely, make a second seam just inside the first seam to take out some fabric. Remember, seam allowances for attaching the bottom piece of the jacket will project past the bottom of the bucket.

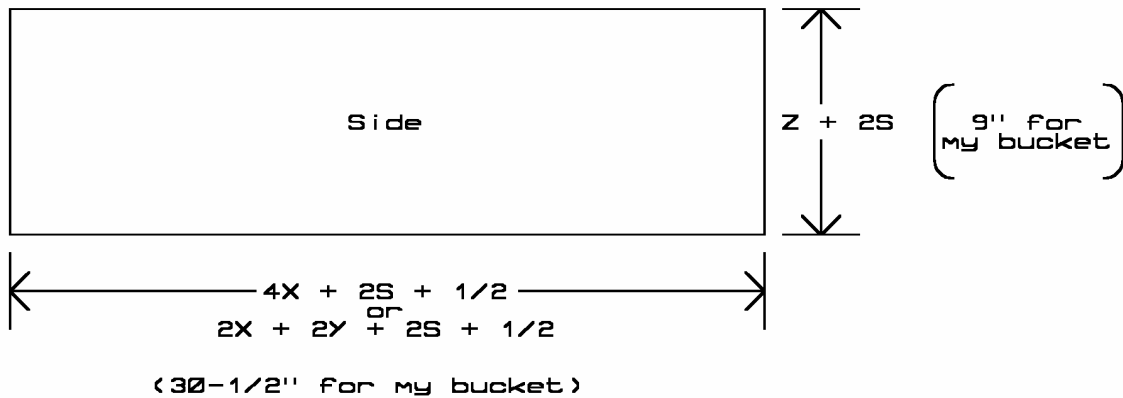

Side Jacket Pattern - s = Seam. I make my seams 1" wide and double them over.

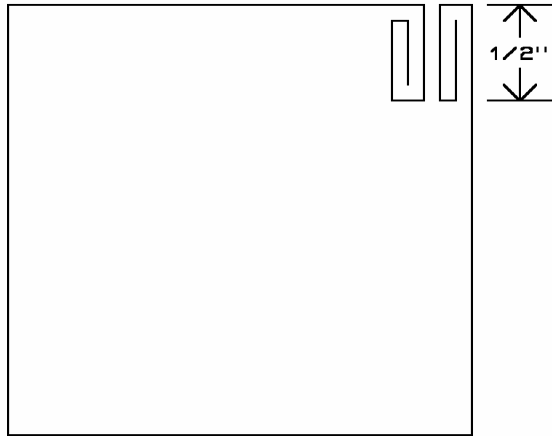

Side Jacket Seams - Top view
(looking down) of side jacket.

Next, lightly mark the location of the eight corners of the bucket on the side jacket, where the Dacron loops will be attached. The Dacron loops are attachment points for the parachute's shroud lines, as well as for link lines to a second module. I've always sewn my Dacron loops into the corners of the bag. If the Dacron loops are sewn to the center of each face, the link lines and shroud lines may tangle up the module's dipole antenna.

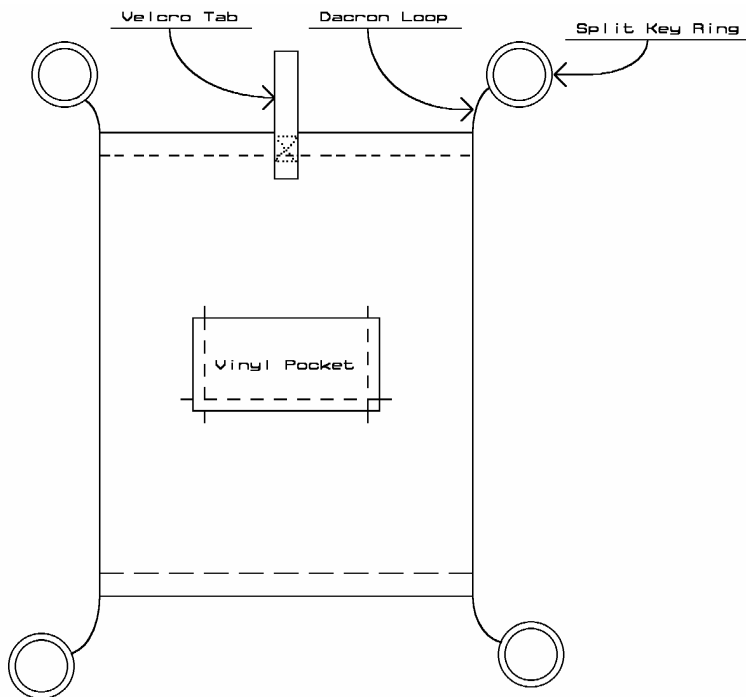

Dacron Loops - Note: Since weight is not a concern, I don't sew Dacron down the sides or across the bottom of the jacket.

Remove the side jacket from the bucket to sew the Dacron loops to the marked corners. Cut eight pieces of $\frac{3}{4}$ " wide Dacron tape into lengths of four inches. Just like the ripstop nylon, it's best to cut the Dacron tape with a hot soldering iron. Fold the Dacron strips in half after they've been cut. Mark the folded Dacron at the one inch midpoint with a pencil. Place the folded Dacron on top of the side jacket, with the folded end of the Dacron rising above the edge of the bag. The open end of the Dacron is sewn to the bag. Align the Dacron's pencil mark with the top of the bag's edge, keeping all the Dacron loops uniform in height.

Sew the Dacron to the ripstop bag with stitches that extend beyond the edges of the Dacron. Use doubled stitches to sew an “X” through the middle of the Dacron, as you want this connection to be strong. Sew the remaining three folded Dacron strips to the remaining corners. Following the same procedure, with the open end of the Dacron loops sewn into the ripstop and the closed ends extending one inch below the side jacket’s edges, sew four more Dacron loops into the bottom corners of the bag’s side jacket. Be sure to avoid sewing the loops onto the seam allowance area at the bottom edge of the side jacket. Note that the Dacron loops are not sewn to the bottom jacket as the weight of lower module may pull the stitches out of the Dacron and ripstop.

Bottom Jacket

The bottom jacket is sewn to the bottom of the side jacket after Dacron loops are attached to the side jacket.

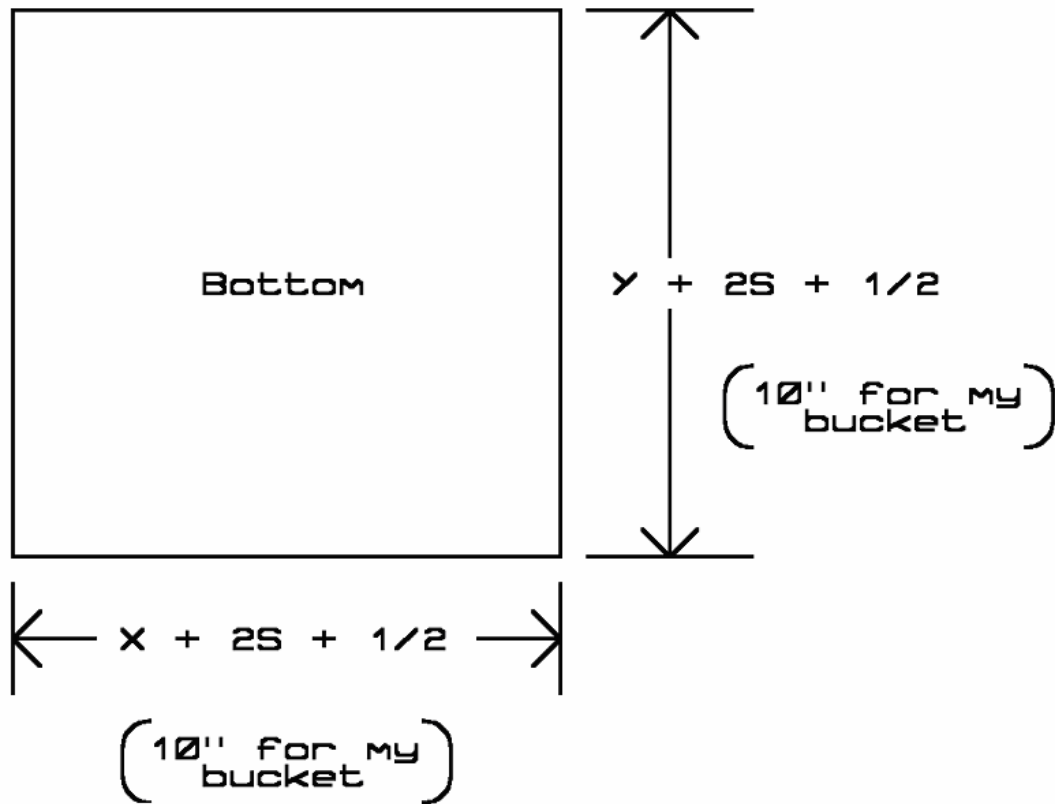

Bottom Jacket Pattern – s = Seam. I make my seams 1" wide and double them over.



Bottom Jacket Seams – Side view of bottom jacket seams.

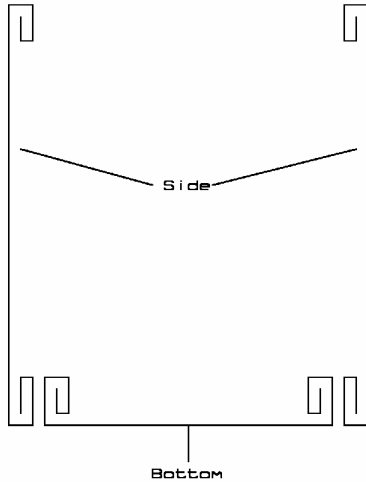

Side and Bottom Seams –
X-Ray view of jacket seams, as viewed from the side.

Place the bottom jacket against the bait bucket with the side jacket on it inside out. Check the bottom jacket's fit against the side jacket, and pin together their seam allowances. Next, remove the jacket from the bucket and sew the two jackets together. Be careful not to sew the Dacron loops into the bottom jacket as you sew the bottom jacket to the side jacket. Flip the jacket right-side out, so the seam allowances are inside and the Dacron loops are outside, and test fit it to the bait bucket. Slide the split key rings into the Dacron loops, with one split key ring per Dacron loop. The split key rings link the bag to the parachute's shroud lines or to other modules.

Hatch Jacket

Place the hatch jacket on top of the bucket, wrong side up. Test-fit the fabric by wrapping the lid as you would wrap a gift, with the fabric smooth and tight on the top and sides, with all the excess fabric in overlapping folds underneath. If it is a good fit, hem the edges under $\frac{1}{4}$ " all around. (If not, cut a new piece of the appropriate size). Next, place the lid on top of the right side of the fabric, and trace very lightly with a colored pencil. Then mark the center of the sides of the hatch jacket.

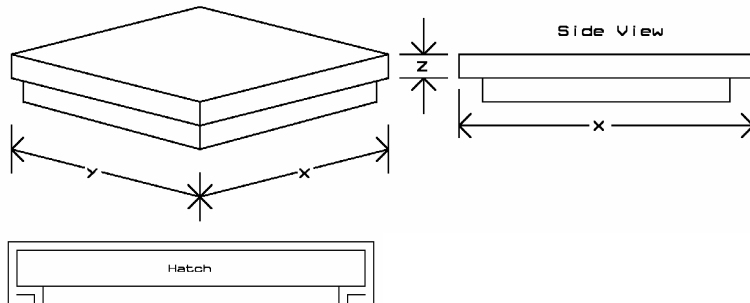

Hatch Dimensions
– Measure your bait bucket.

Hatch Seams –
Side view of hatch with seams.

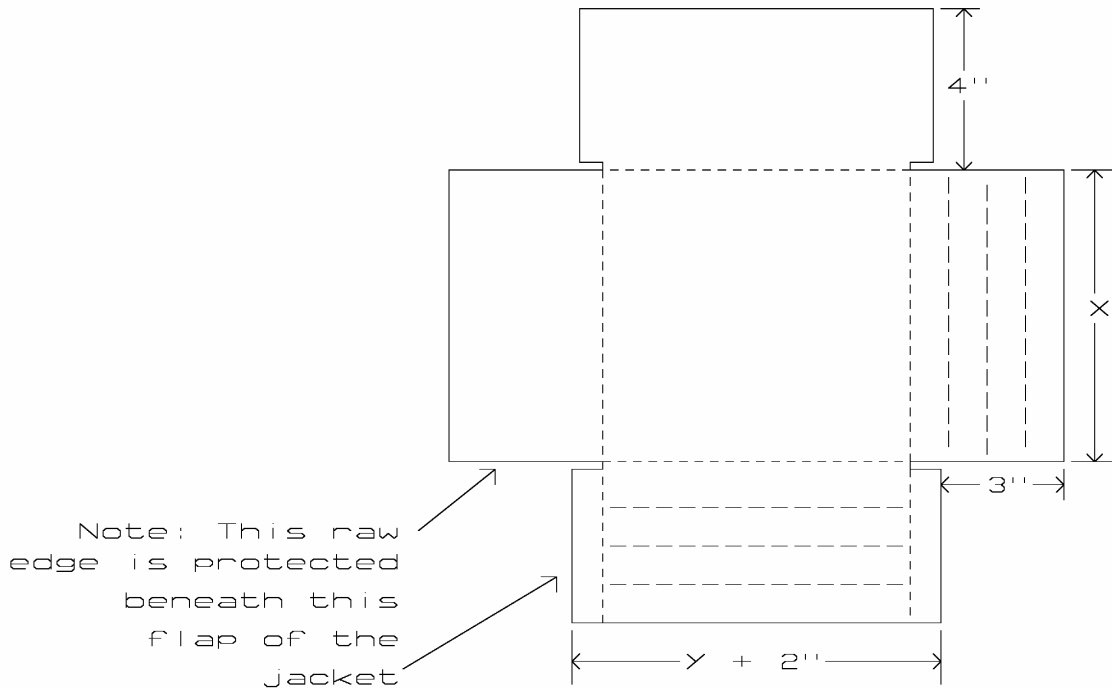

Hatch Pattern – Using 1" seams.

The hatch is attached to the airframe with Velcro tabs. Cut four strips of Velcro to a length of 2-1/2". Select which face (fuzzy or hooks) to attach to the side jacket, and the other face sew to the hatch jacket. With the side jacket on the bait bucket, mark the center of the top edge of each face. These marks are where the Velcro strips are sewn. Remove the jacket and mark the center lines one inch below the top of the jacket. Place the first piece of Velcro on the center line and place its bottom end against the one inch mark. Be sure the fuzzy face of the Velcro is face down before sewing. After being sewn to this mark, the Velcro tabs extend 1-1/2" above the top of the side jacket, leaving enough Velcro tab to secure to the hatch. Sew the Velcro tab into place just like the Dacron strips were sewn. The other halves of these Velcro tabs will be sewn to the hatch jacket. Place each tab, fuzzy side up, over a center-side mark on the hatch jacket, with the bottom of the tab aligned with the traced edge of the lid. Sew the tabs down completely.

Because a tight fit is necessary, the hatch jacket is sewn onto the lid of the bait bucket by hand. Place the hatch jacket face down on a flat surface, and place the lid upside down on that, being careful to align it with the edges where the Velcro tabs were sewn. Wrap the fabric around the jacket tightly and neatly, as if you are wrapping a gift. Use strips of masking tape to secure the fabric in place while sewing the jacket on. Use simple over-hand stitches to hold the edges together, keeping the fabric taut. For extra security, put a drop of Fray Stop^G or CA adhesive^H on the knots in the thread when you are finished.

The name and flight history of the capsule is carried on a folded card. Make the folded size of the card the same size as a business card. The card is slipped into a clear vinyl pocket sewn into the jacket. (Use a business card if the name of the capsule is not yet printed.) Cut the vinyl 1/2" larger than the size of a business card, or 2-1/2 inches by 4 inches. Replace the side jacket on the bait bucket and mark a location for the name card of the capsule. Remove the jacket and sew the clear vinyl to the jacket face. Place the business card between the jacket fabric and vinyl. Then sew around the vinyl. This ensures the pocket is sewn large enough to hold the business card.

Velcro is also useful for attaching patches or small signs to the airframe. At this point decide if you want additional Velcro strips sewn to the side jacket. If so, slide the side jacket on the bait bucket and mark the location of any desired Velcro strips. Remove the jacket and sew the Velcro into place.

Because of the tight fit, the hatch jacket is sewn onto the lid of the bait bucket by hand. Use strips of masking tape to secure the Velcro closures of the jacket to the lid before beginning to sew the jacket on. Use a simple over-hand stitch. For extra security, put a drop of Fray Stop or CA adhesive on the knots in the thread.

Completing the Bait Bucket Airframe

Cut a notch, approximately 1/8th of an inch on a side, at the top edge of the bait bucket centered on a side face. This is the location the antenna coax passes through. If the capsule uses a dipole antenna, then make a boom to hold the antenna and bolt it to the hatch. Read Chapter Five, Section Three for directions on making antenna booms from Styrofoam and 1/32" plywood. If instead of a dipole, the capsule uses a J-pole antenna, then an antenna boom is not required. Read Chapter Four, Section Three about making antennas. Read Chapter Two, Section Three on making a tracker for the bait bucket airframe.

Your airframe is now complete. This design gives the opportunity to quickly undertake your first mission. However, you may soon find that dimensions are too tight inside the bait bucket for many experiments. At that point, this airframe will make a fine back-up tracker as you move on to more complex missions.

2.0 The NearSys Airframe

The airframe described below was developed in the spring of 1999. It was the author's third generation airframe, after the Asimov (an unwieldy design) and Asimov II (made from Kevlar). The current NearSys design is lightweight, warm, and simple to construct. The airframe is constructed from inexpensive and commonly available materials (unlike the Kevlar in Asimov II). Most of the weight of a mission in a NearSys capsule is experiments and the flight computer, rather than airframe infrastructure. Temperatures inside the NearSys airframe drop no lower than freezing, except briefly during early descent when wind chill cools the interior.

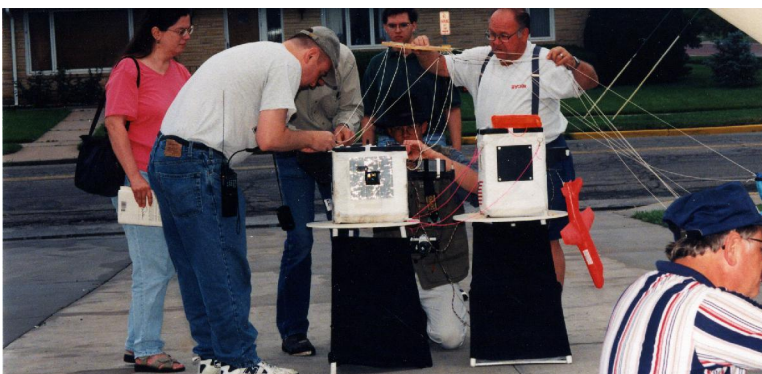

NearSys Airframe – Prepping a KNSP near spacecraft for launch at the Cosmosphere, Hutchinson, KS, Summer 1999. The near spacecraft consists of two modules tethered together.

2.1. Overview of the NearSys Airframe

The goal is to design an airframe with the flexibility of the Space Shuttle (but nowhere near the cost!). Usually the Space Shuttle airframe requires no modification for each flight; instead, experiments are built to fit the Shuttle. Not having to make modifications for each flight prevents the Space Shuttle

from being any more expensive to fly. The NearSys design outlined in this chapter has a similar flexibility. There is no need to cut up the airframe to add new experiments to the flight manifest. The NearSys airframe is constructed of Styrofoam sheets glued together to form a box. On each vertical side of the airframe is a square-shaped access port. Three are large experimental ports, which are places to mount experiments to the near spacecraft. The one smaller port, a control port, is used for controlling near spacecraft power and for programming the Central Computer/Programmable Sequencer (CC/PS), which is the capsule's flight computer.

Optional layers of aluminized Mylar¹ and scrim cover the exterior of the airframe. The layers add additional insulation to the airframe, the benefits of which are the subject of ongoing investigation. A layer of polyurethane foam on the bottom of the airframe provides shock absorption upon landing. Protecting the foam rubber and the outer layer of Mylar from abrasion is a jacket of spinnaker (ripstop) nylon. This abrasion jacket has square holes corresponding to the open ports of the airframe. Sewn at the eight corners (four on the top and four on the bottom) of the abrasion jacket are loops of 3/4-inch wide Dacron tape. The loops extend one inch beyond the edge of the abrasion jacket. One-inch split rings are fitted to the Dacron loops. Link lines use the split rings to connect either two modules together or to connect parachute shroud lines to the module. Finally, there are strips of Velcro sewn to the abrasion jacket. Velcro straps securely lock the module's hatch into place. Additional Velcro straps on the abrasion jacket attach mission patches to the near spacecraft and mount lightweight (usually passive) experiments to the outside of the near spacecraft.

2.2. Constructing the Airframe

The NearSys airframe is easy to design and build. In less than thirty minutes you'll get a feel for what your near spacecraft will look like. The NearSys airframe is designed to be lightweight and reasonably warm inside.

2.2.1. Lists of Materials and Tools

You'll need the following tools to construct the airframe:

- Exacto Knife with a long blade
- Straight Edge
- Pencil
- Hot Glue Gun
- Stationary Belt Sander (optional, but useful)

You'll need the following materials to put the above tools to work constructing airframes:

- One four foot by eight foot sheet¹ of 3/4" thick Styrofoam panel
- Roll of Styrofoam tape²

Notes:

1. This is the type of foam paneling used to insulate homes and is either pink or blue in color. Panels of several thicknesses are available, but the 3/4" sheets have a sufficient thickness. Thicker sheets will provide greater insulation, but are harder to cut with Exacto knives. The thinner sheets save only a little weight and money, while being more fragile. It is better to use thicker sheets if you cannot find 3/4" foam panels. The tiny increase in overall capsule weight offsets the increased fragility of thinner sheets. A sheet of polystyrene foam costs about twenty dollars and enables you to build a fleet of near spacecrafts. Personally I think the pink colored foam has a harder surface than the blue colored foam. If true, this makes the pink colored foam less likely to dent.

2. Styrofoam tape is used to wrap the bodies of Styrofoam stunt and combat gliders. It's available in many colors at your local hobby store.

2.2.2. Procedure

First remove the thin plastic film covering the foam panel. You will cut six pieces of foam to make an airframe. Four pieces are for the sides and two for the top and bottom. The top and bottom pieces have identical dimensions. It's easier to construct the airframe if the side panels have identical dimensions, but not necessarily those of the top and bottom. It is the author's experience that most experiments can be fitted to six-inch square panels. This necessitates port openings of 5.25 inches on a side. Six-inch port panels require airframes measuring at least ten inches on a side. Most of my early airframes are twelve inches tall. So, let me recommend making your first airframe with outside dimension of either twelve inches cubed or twelve inches tall and ten inches on a side. Airframes this size have sufficient volume for large devices like camcorders. Making airframes with larger dimensions encourages adding more than six pounds of weight in each airframe.

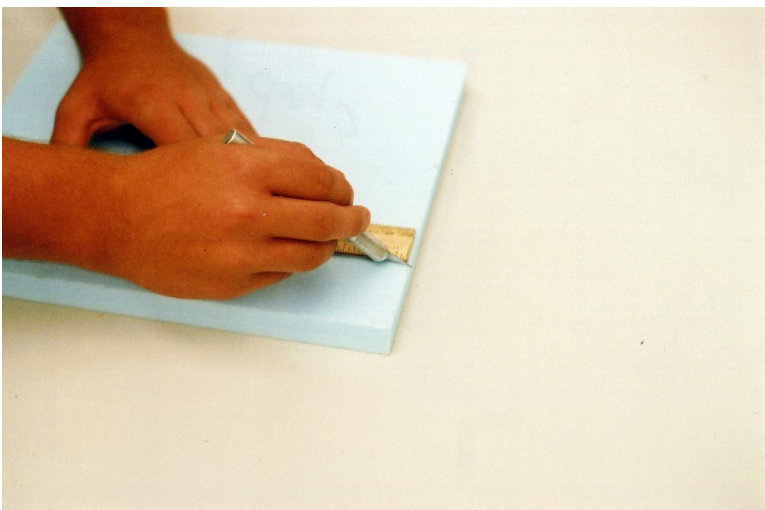

Cutting Foam – Use a sharp, long blade for best results.

Once the plastic film is removed, mark the Styrofoam sheet with a pencil. Use a T-square and meter stick to get square corners and straight edges. Cut the panels with a sharp Exacto knife and straight edge. Use a long blade on the Exacto knife and make several passes through the foam to cut a smooth edge. Use a new blade (sharp) to prevent the blade from grabbing the foam as it is cut. Dull blades grab and fracture the foam, pulling little chunks out of the cut and creating a ragged edge. Make cuts with the knife held perpendicular to the surface of the foam. Label each panel as it's cut out from the foam. This is especially important if the airframe does not have equal depth and width. Cut out all

the panels before gluing the airframe together. Do not cut out the airframe ports until after the airframe is glued together.

The airframe panels are glued together with hot glue. The hot glue gun and glue sticks are available at your local hobby or arts and crafts store. Read the glue gun's instructions before you start using hot glue. Most hot glue comes in 1/2-inch diameter plastic sticks. Sticks of glue are fed into an electric heater mounted into a pistol grip. Be careful with glue guns as the glue gets hot enough to cause serious burns. It's useful to have a temperature control on the glue gun, so that you can prevent the glue from getting so hot that it melts the foam. You will need to unplug the glue gun occasionally if it does not have temperature control.



Gluing Styrofoam Panels – Don't let the glue get so hot that it begins melting into the Styrofoam. Use a good bead of glue and wipe the corners, being careful not to burn your fingers.

An extra set of hands is useful during the construction of the airframe. Melted hot glue does not cool too quickly, so there is sufficient time to assemble the panels. Find the first two panels to glue together, a side and bottom panel. Test fit their alignment before gluing them together. Now apply a bead of glue to one panel and stick it to its neighboring piece. Hold the panels perpendicular to each other as the glue cools.

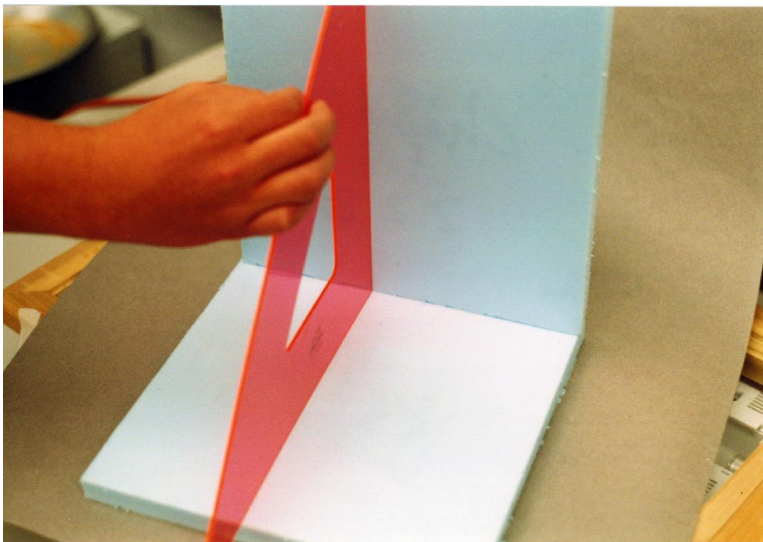

Aligning Panels - Use a square or similar tool to true up the airframe as the hot glue cools.

I find that a small triangle is useful for squaring up the panels as I glue them together. Glue the remaining three side panels to the bottom panel. Be sure to glue the side panels to each other when gluing them to the bottom panel. DO NOT glue the top panel (the hatch) to the airframe. Trim the edges of the airframe after the glue has cooled. Better still is to trim the airframe edges with a stationary belt sander. Wear a filter mask when trimming the airframe box with a sander. You will end up with a rigid and lightweight box with smooth joints. To further strengthen the airframe, wrap a length of Styrofoam tape around the top of the airframe. This keeps the top edges of the airframe from pulling apart over time.

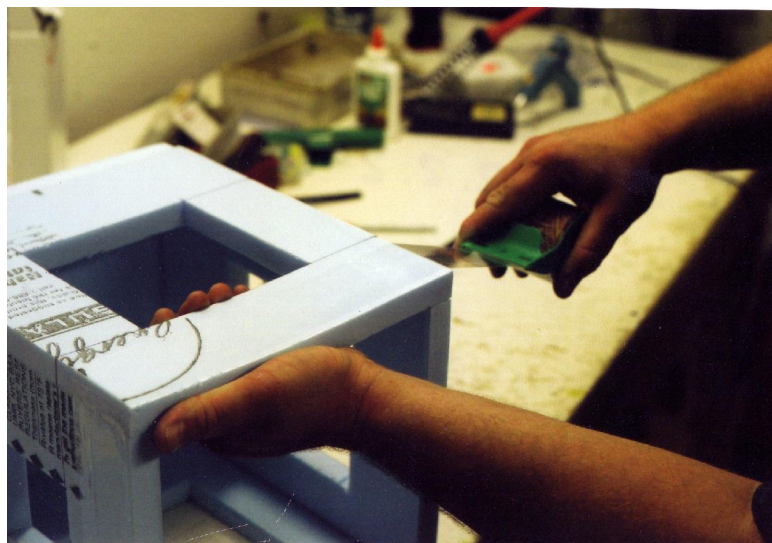

Taping a NearSys Airframe - Only the top really needs a wrap of tape, the bottom is solidly glued to the base.

2.3. Cutting Access Ports

Now cut the access ports into the airframe. Access ports must to be high enough off the bottom of the airframe for the avionics to have sufficient clearance. I recommend cutting the access ports at least two inches from the bottom of the airframe. Wait until after you construct your first near spacecraft before deciding you need lower access ports. If you need lower ports, place them on sides that are away from the avionics (the avionics can be located away from the center of the airframe). The access ports in my airframes are centered on the sides of the airframe. Though not a requirement, I recommend the ports be centered on your first airframe. It is the author's personal preference to cut the top of the control port flush with the top of the three experimental ports. The diagram below illustrates the recommended dimensions and locations of ports. Use a T-square to draw the locations of the ports and use a sharp Exacto knife to cut out the access ports. Save the cut-out squares to make port covers.

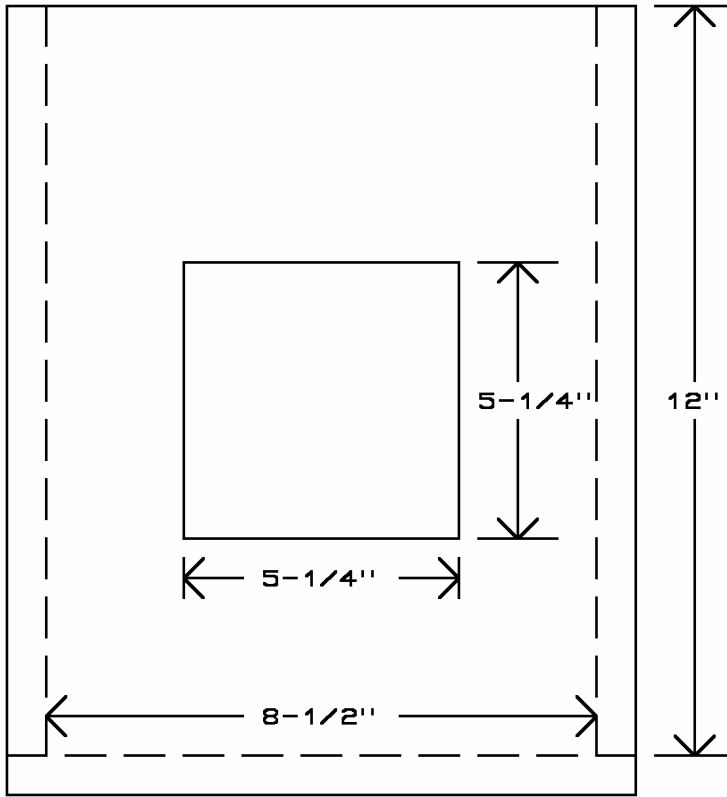

Large Access Ports – Cut these holes into three sides of your airframe.

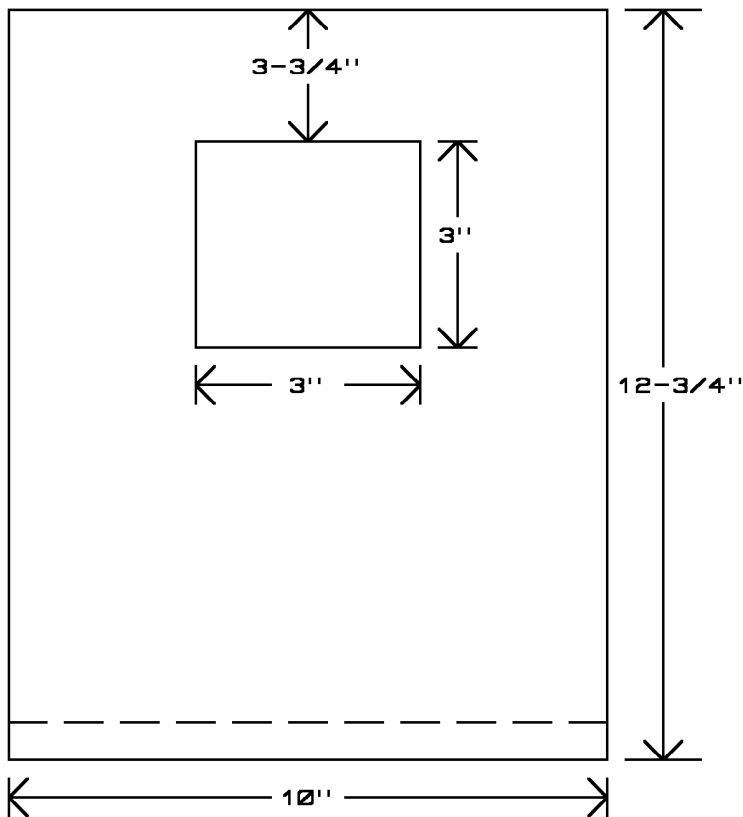

Control Port – Cut this smaller hole in the remaining side.

The control port is where the power and programming panel is mounted. To secure this panel, epoxy a plywood-reinforcing frame to the foam around the control port. Use 1/32" modeling plywood for the frame. Construct the reinforcement frame by cutting a four inch square piece of 1/32" modeling plywood. Then remove a three-inch square from the middle of the plywood. Epoxy this square frame inside the airframe, centered on the control panel. This creates a square frame with a 1/2" border inside the airframe. Use small strips of masking tape to hold the frame in place while the epoxy sets.

3.0 Covering Airframes with Multi-Layer Insulation (MLI)

At this point you have a Styrofoam box with an opened top. Cut out of its four sides are three large square holes and one small square hole. The next step is to cover it in a jacket of multilayer insulation (MLI). A similar type of MLI is used to insulate spacecraft. In spacecraft construction, a jacket of MLI acts like a lightweight and unbreakable Dewar (thermos for you non-techies). MLI works best in a hard vacuum as is found in space. Near space does not obtain this level of vacuum, so the MLI may not be as effective as I hope. Ideally, adding MLI to the airframe keeps the interior of the module warmer (see the Good to Know section of this chapter) by preventing thermal radiation from escaping from the airframe. In science labs, inexpensive MLI substitutes like this are used to insulate cryogenic pipes, or pipes carrying liquid gases like nitrogen. Space certified MLI is very expensive, on the order of one dollar per square inch, but I can show you an inexpensive substitute.

3.1. List of Materials

If you decide to use MLI, you'll need the following materials:

- A package of space blanket
- Two yards of plastic wedding veil material
- Transparent tape, 3/4" and 2" wide

3.2. Making the MLI

Near space MLI is constructed from alternating layers of aluminized Mylar and scrim. The source of aluminized Mylar is a space blanket, and the scrim is plastic wedding veil material. These materials are available from your local Wal-Mart. A few dollars purchases enough materials to insulate an entire near space fleet.

Aluminized Mylar forms the walls of a Dewar while the scrim maintains the separation between the layers. The aluminum coating on the Mylar cuts down on the amount of radiation cooling by reflecting thermal radiation back into the airframe. The scrim minimizes thermal conduction by maintaining physical separation between the layers. A vacuum between the layers reduces the amount of heat loss by convection.

3.2.1. Covering the Sides of the Airframe

Wrap the bottom and sides of the airframe with at least three layers of Mylar and two layers of scrim. Wrapping the sides of the airframe is easier if you lay the airframe on its side. Do not unroll the space blanket yet. Instead lay the roll of space blanket up against the side of the airframe with some space blanket extending above the top of the airframe and below the bottom of the airframe. Now cut the roll of space blanket to the proper length. The proper length is about one inch above and below the top and bottom of the airframe. By cutting the rolled up space blanket, you have quickly cut a rolled up length of space blanket to the proper width. Roll up the scrim material and cut it in the same way. You'll trim the space blanket and scrim to the proper length later.



Wrapping airframe in MLI -
Wrap the airframe in a strip of space blanket and scrim.

Unroll some of the space blanket and scrim. Use a few, short lengths of $\frac{3}{4}$ " transparent tape and tape the end of the space blanket to an edge of the airframe. Keeping the space blanket tight, wrap a single layer around the airframe. Now lay the end of the roll of scrim on the space blanket. Use a few pieces of $\frac{3}{4}$ " tape and tape the scrim to the space blanket. The scrim doesn't tape well, so rub the tape down. Continue wrapping the space blanket and scrim around the airframe. Keep a layer of scrim between successive layers of space blanket. Stop wrapping scrim after two layers. Finish the MLI with an outer layer of space blanket. When complete, you will have two layers of scrim between three layers of aluminized Mylar (space blanket). Hold the last wrap of space blanket to the airframe with a few pieces of tape as you wrap. You may find that a second piece of scrim or space blanket is needed. If so, tape the second pieces to the first pieces with just a little bit of tape.

3.2.2. Covering the Bottom of the Airframe

Repeat the same process of cutting scrim and Mylar for the bottom. But instead of wrapping the bottom of the airframe, you'll place several sheets of Mylar and scrim on the bottom of the airframe.

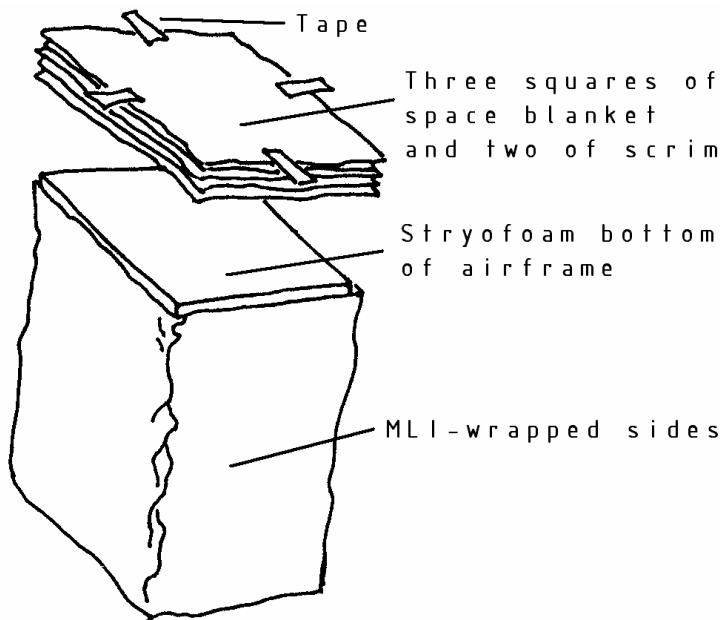

Covering the Airframe Bottom with MLI

After cutting the scrim and Mylar to width, unwrap them and cut the proper sized squares out of the material. Layer a piece of scrim between two layers of Mylar. Repeat this until you have three layers of Mylar separated by two layers of scrim. Use a minimum of tape to hold the layers in place.

3.2.3. Taping Up the Loose Edges

Carefully trim up the excess length of MLI that is hanging over the edges of the airframe. Use the wider tape to tape the side and bottom MLI together. Also run tape over the top edge of the sides MLI. There should be no open ends of the MLI at the bottom of the airframe and the top edge should be reinforced with tape.

3.2.4. Cutting Ports

Use an Exacto knife to poke a hole in the MLI at each corner of a port. Then use scissors to cut across the open port diagonally, leaving an "X" cut into the MLI covering each port location. Trim away most of the excess MLI, leaving about a two-inch border. Wrap and tape the remaining two-inch border of MLI over the edges of the port. Tape the open MLI with two-inch wide transparent tape to the edges of the port. Now the airframe is covered and the ports opened up again.

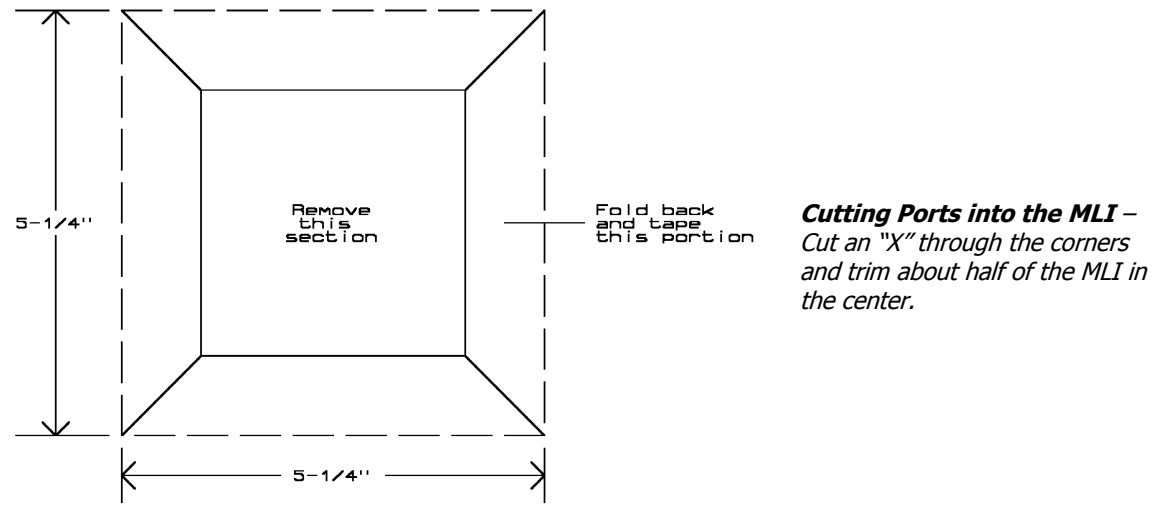

4.0 A Simple Landing Bag

Now it's time to add the landing bag. I added a landing bag to my near spacecraft Asimov II about one year after the Mars Pathfinder landed on Mars in July 1997. I did so because I became concerned about the force of landing possibly denting or cracking the airframe, especially if the near spacecraft recovered on cement or asphalt. Originally I wanted to design an inflatable landing bag, but determined it would add too much weight and complexity (however, it will be a project for the future, see Chapter 13). I didn't want to add a previously inflated bag to the bottom of the capsule as the low pressures of near space would cause it to expand and possibly burst. I then came up with the idea of using a foam rubber filler between two sheets of fabric, similar to the Therm-a-rest¹ camping mattress and somewhat similar to the deployed landing bags of the Mercury space capsules. Air is free to leave the bag as the air pressure drops during a flight (when the protection is not needed), but returns to the bag during descent to help cushion the capsule at landing.

4.1. List of Materials

You'll need the following three items to make a landing bag:

- One-inch thick foam rubber sheet
- One-quarter inch thick foam rubber sheet
- Silicone glue

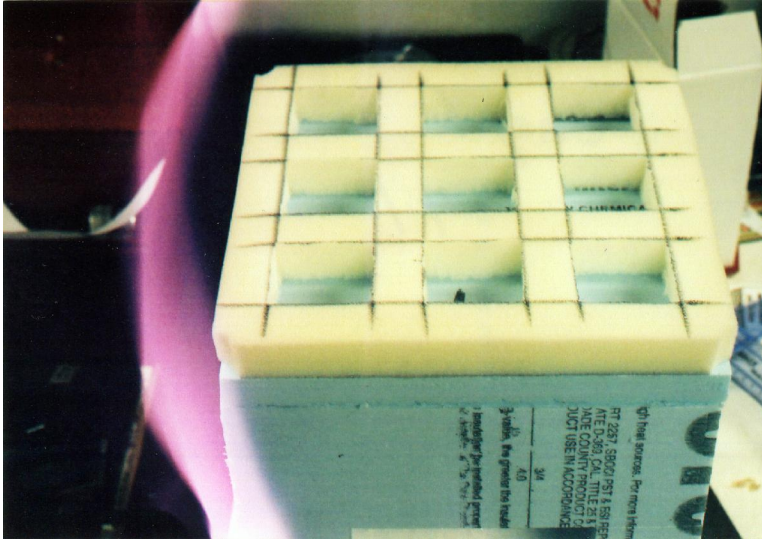

Landing Bag - The foam rubber of the landing bag. We chose not to wrap this airframe in MLI as part of an experiment.

4.2. Procedure

Cut a piece of one-inch foam rubber to fit the bottom surface of the airframe. Since an entire sheet isn't required, cut holes out of the foam rubber sheet, with each one about two inches across. The foam rubber looks like a piece of Swiss cheese after being cut and has less weight. Attach the sheet of foam rubber to the bottom of the airframe, over the MLI, with small dabs of Silicone glue (RTV). Next seal the holes with a 1/4" sheet of foam rubber. Do this by cutting a second piece of foam rubber the same size as the first sheet (the size of the bottom of the capsule). Use RTV to glue the second sheet over the first sheet (the one-inch thick layer). Leave the airframe upside down and put a sheet of Styrofoam on top of the foam rubber. Add a little bit of weight on the Styrofoam sheet to press the foam rubber down and let the RTV set up.

5.0 The Abrasion Jacket

The MLI covering the airframe will not last many recoveries without tearing. To protect the MLI, cover the airframe with a bag of spinnaker (ripstop nylon) kite sail fabric.

5.1. List of Materials

You'll need the following materials to make the abrasion jacket

- Two yards of spinnaker (ripstop) nylon¹
- One yard of 3/4" Dacron tape²
- Eight 1" split key rings³
- Package of sew-on Velcro tape
- One yard of clear plastic vinyl⁴

Notes:

1. Purchase the spinnaker fabric from a kite store like, Into the Wind (www.intothewind.com)
2. Purchase the Dacron tape from Into the Wind, also. It comes in two colors, black and white
3. The split rings are the type used for key rings. They're available from hardware or arts and crafts stores.
4. The clear plastic is available at fabric stores, where it's used to make items like plastic seat covers.

Note: Kite sail spinnaker comes in a multitude of colors, allowing for some pretty wild color schemes.

5.2. Procedure

After buying the spinnaker, iron it to flatten it and to remove the wrinkles. Be careful to use the proper iron setting so you don't melt the fabric.

5.2.1. Jacket Construction

Draw a simple pattern for a cube that fits the airframe. Don't forget the foam rubber on the bottom of the airframe or else you won't make your cube large enough for the landing bag. Also don't forget that you'll need to add extra fabric for a seam allowance, at least one inch. This gives enough fabric to double the seam over twice. Below is a typical pattern for an airframe.

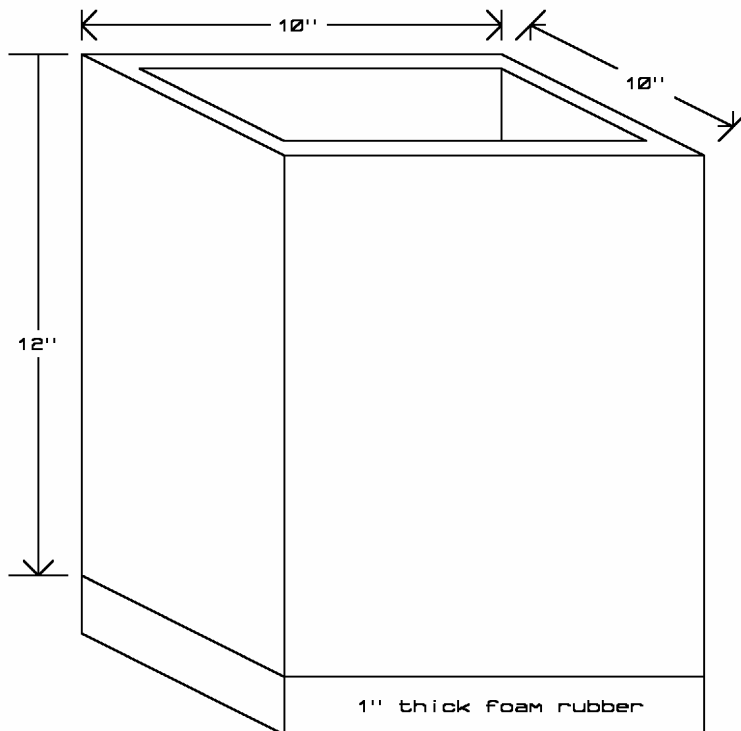

Airframe Dimensions – This airframe is 10"x10"x12" PLUS 1" foam rubber on bottom.

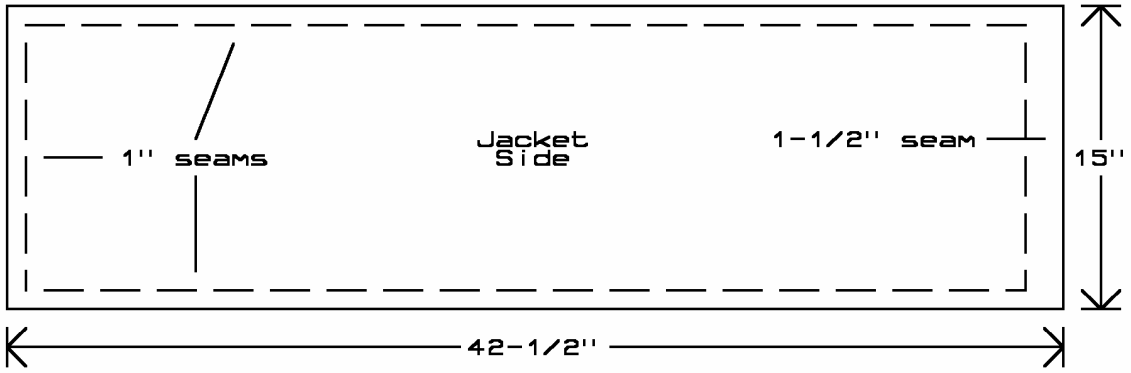

Side Pattern – Cutting the jacket a little large lets you trim the jacket to the exact size by taking it in a little.

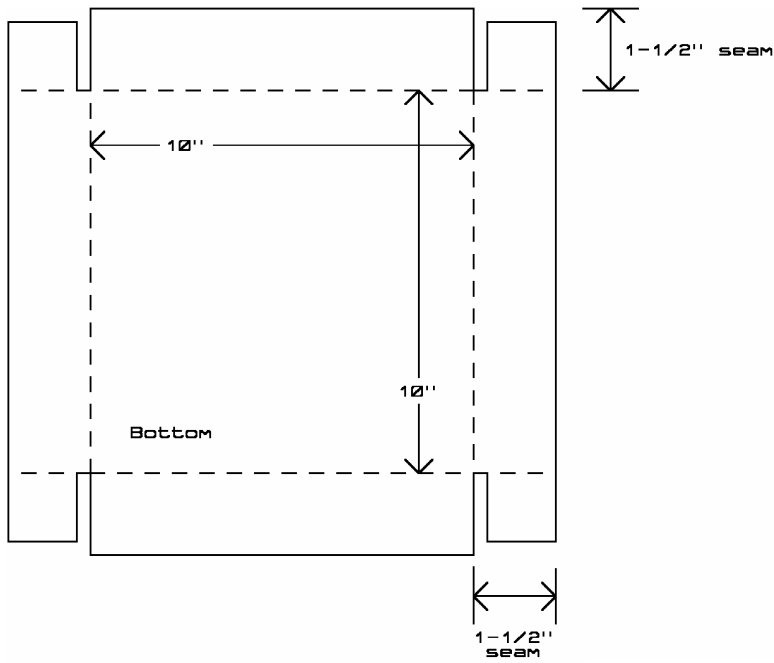

Bottom Pattern

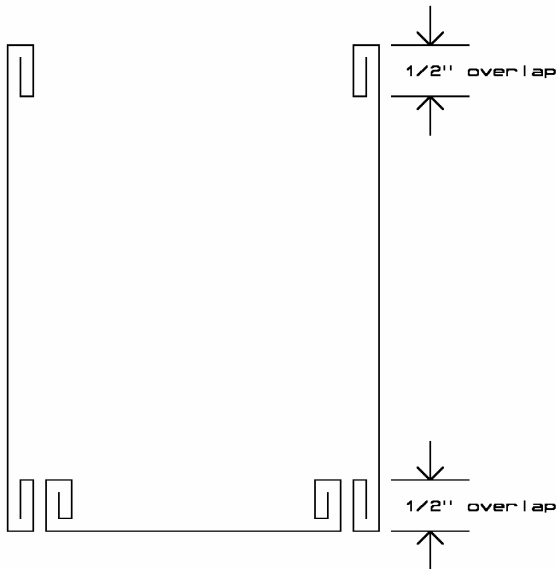

Seam Detail – X-Ray side view of sewn jacket.

Spinnaker marks easily with colored pencils. Whatever the color you choose to make the abrasion jacket, use a contrasting color to mark on it. Be sure you only mark on the back of the fabric and not on the surface that will show on the outside of the airframe. Cut spinnaker using a soldering gun with a cutting tip. This creates a hot cutter that melts and seals the strands of nylon woven into the fabric. Into The Wind, Wal-Mart, and some hardware stores sell soldering irons with hot cutting tips. Use a metal straight edge, or other heat resistant straight edge, as a guide when cutting the fabric. If you don't have access to a hot cutter, then cut the spinnaker with scissors. Don't attempt to melt the ends of the spinnaker with a lighter or candle, as doing so results in uneven edges in the cut fabric.

After cutting out the pattern, fold the seams over and run your finger nails over them to crease the spinnaker. I find this easier and faster than ironing the creases in. Hem the edges first, and then you can begin sewing the abrasion jacket into a box. Remember, you don't have to keep a uniform color for your near spacecraft. For example, use black fabric for the sides and white for the top and bottom.

5.2.2. Dacron Link Loop Construction

Barrel swivels and split rings on the abrasion jacket connect modules together or attach the shroud lines of the parachute to a module. Folded loops of $\frac{3}{4}$ " wide Dacron tape secure the one-inch split rings to the abrasion jacket. Purchase the Dacron tape from a kite store when you order the spinnaker nylon. Use the soldering iron to cut eight strips of Dacron, each four inches long. Now fold them in half and crease the fold. Sew the eight Dacron strips into the top and bottom corners of the abrasion jacket. Lay half of the first Dacron loops along the edge of a corner of the abrasion jacket, with half the loop extending beyond the edge of the jacket. Now sew the Dacron onto the abrasion jacket. I like to sew the Dacron down with a square with an "X" through its middle. When finished sewing the Dacron, pull on it to make sure it won't pull loose. Now do the other seven strips. Later you'll slip the split rings on these loops.



Dacron Link Loop - A four inch strip (of doubled over) Dacron is sewn into all eight corners of the abrasion jacket. One-inch split rings are slipped into the Dacron loops so that modules can quickly be linked together with link lines.

5.2.3. Velcro Hatch Closures

Four strips of Velcro secure the hatch to the airframe. The strips extend above the top edge of the abrasion jacket and wrap partway around the sides of the hatch. Velcro on the hatch sticks to the closures, securing the hatch. Four strips are sufficient because of the hatch's low weight.

Place the airframe inside the abrasion jacket. At the top edge of the abrasion jacket, mark the center of each face. Because of the position of the Dacron loops in the corners of the abrasion jacket, sew the Velcro strips in the middle of the airframe sides. Cut four strips of Velcro to a length of three inches. Sew only the bottom one inch of each strip of Velcro to the abrasion jacket. Be sure to place the latching side of the Velcro against the abrasion jacket. The two inches of Velcro above the jacket go over the sides of the hatch leaving about two inches to wrap over the top of the hatch. After sewing the Velcro hatch closures, tug on them and make sure they're secure.



Velcro Closure - Centered at the top of each face of the abrasion jacket is a Velcro tab. It is used to secure the hatch to the airframe.

5.2.4. Making the Ports

Test fit the jacket on the airframe. Notice that when it's covered with the abrasion jacket, the foam rubber on the bottom of the airframe forms a cushioning landing bag. Using a fine tip felt marker, mark the corners of the port openings. Use the hot cutter and cut an "X" through the middle of each port opening. You can do this while the abrasion jacket is on the airframe.

Remove the abrasion jacket from the airframe and set it back down on your cutting surface. With the hot cutter, remove some of the excess material from inside the open ports. Make sure however, to leave a one inch seam allowance to hem. Now fold back the port seams and crease their edges. Sew around the open ports, sealing the seam allowances inside the abrasion jacket. I like to make two laps around the port openings.

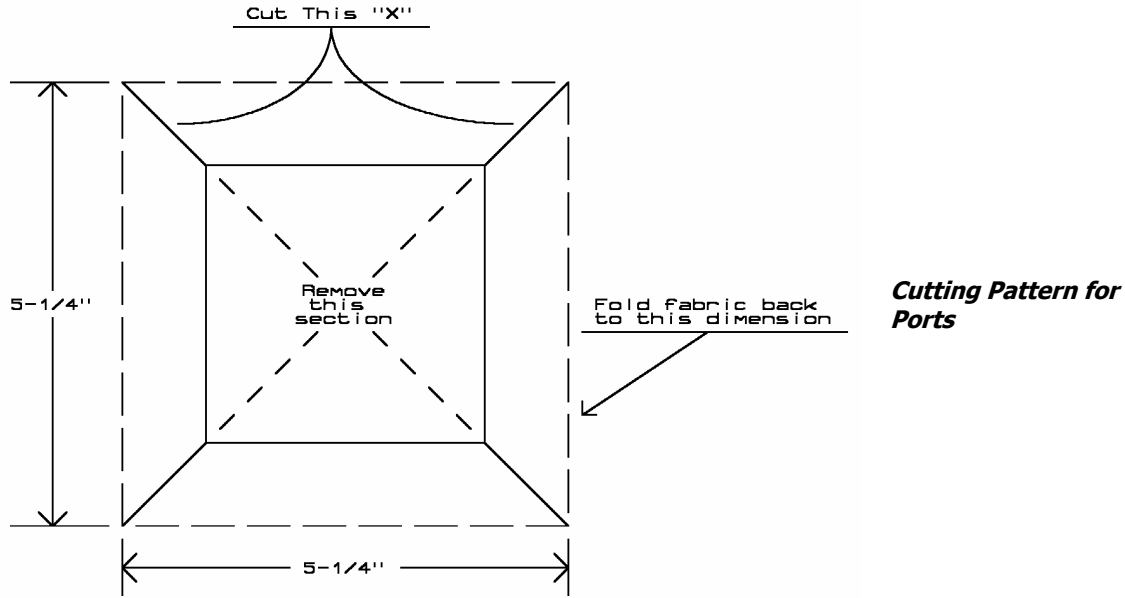

5.2.5. Optional Items to Add to the Abrasion Jacket

Next decide if your airframe is to have any of the following items sewn to it: removable mission patches, clear plastic pockets for cards, or items like a flag. You may want to place sponsor's logos or other temporary flight patches on the outside of the airframe. You can print mission patches on a color printer and afterwards, laminate them. On the back of the lamination put sticky Velcro patches. Another item to add is a clear plastic pocket. The pocket can hold a business card sized card with the capsule's name and flight record. The card lets you add professional lettering to the airframe. Finally, embroidered patches can be added to the airframe. Patches like the nation's or state's flags are good. Another option is to have an embroidery shop make a custom patch for the airframe.

Velcro for Mission Patches

If you decide to add Velcro strips for mission patches, then select good locations for them on the airframe and mark them with a pencil. A good location is at least two inches away from the edges of a port, where the Velcro cannot interfere with panels used to attach experiments to the airframe. It's best to locate patches either above or below ports, and not to their sides. You'll be sewing Velcro strips at these locations to hold the patches. Four-inch long Velcro strips seem to be long enough. Cut as many strips of Velcro as needed. Watch which type of Velcro you use here. All Velcro strips for mission patches must be the same face or type of Velcro.

Vinyl Pocket

Use a business card as a pattern. Cut a rectangle of soft vinyl 1/2" larger than the business card. Lay the business card on the abrasion jacket in the position desired. Lay the vinyl on top of the card and sew the vinyl to the jacket around 3 sides of the card. The card is a guide to prevent you from sewing the pocket too small to hold a business card.

Now create a capsule name in a word processor and print it on card stock. Cut the card twice the size of a business card and fold it over. When cutting the card, place the capsule name on the bottom half of the card. When folded, the card's open end is at the bottom of the card, and at the bottom of the pocket. If the card fold is at the top of the card, then the card continuously pushes the pocket open.

Inside the card, I record each flight a capsule makes. The mission name, date, and altitude are recorded. I also add a build date for the capsule.



Patch and Vinyl Pocket - The vinyl pocket in the abrasion jacket. The pocket can hold information and a phone calling card instructing a finder to call the owner. In this case, the pocket holds a card with the name of the module and its flight statistics.

Embroidered Patches

I like to sew a permanent American flag on one face of my airframes. I use either four-inch cloth flags from small Fourth of July decorations or more substantial embroidered patches. Flag decorations come stapled to thin wooden dowels. I remove the staples and cut the excess fabric free of the flag. These are cloth flags and they are likely to fray. Treat them gingerly until after sewing them to the abrasion jacket.

Embroidered patches come with either a sticky backing, iron-on backing, or without any backing. Do not use the sticky backed patches as the adhesive gums up the needle on the sewing machine. I don't believe the iron-on backing will stick well to the smooth spinnaker. If you're planning to sew a flag to the abrasion jacket, place it on the jacket now and mark the locations of its corners.

5.2.6. Finishing Up

Put the abrasion jacket back on the airframe and try it for fit again. Everything on the jacket should line up with everything on the airframe. Slip a one inch split ring on all eight of the Dacron loops. If you need to put additional lettering on the airframe, use a laundry marker, as they are permanent markers. I suppose there's no reason you couldn't create nose art, like the WW II bombers.



Completed Airframe, sans Hatch - The completed airframe. You'll add the power and programming panel after assembling the flight computer.

6.0 The Module Hatch

The hatch consists of a sheet of Styrofoam covering the open top of the airframe. It's held in place with Velcro straps for quick and easy doffing and donning. The outside face and the edges of the hatch are covered in spinnaker while the inside may be covered with colored plastic. Mounted to the top of the hatch is a handle to make lifting and positioning of the hatch easier.

6.1. List of Materials

You'll need the following materials to complete the hatch

- Styrofoam sheet, 3/4" thick
- Sheet of colored Mylar¹
- Ripstop Nylon
- Four inch plastic handle and mounting hardware²
- 1/16" plywood sheet
- Sew-on Velcro
- One sheet of poster board

Notes:

1. Do not use aluminized Mylar on the hatch if there is a GPS receiver inside the near spacecraft. Tests performed by the Treasure Valley Near Space Program (TVNSP) have shown that the Garmin Etrex GPS receiver gets a satellite lock through many inches of Styrofoam, but cannot get and maintain a lock through a layer of aluminized Mylar.
2. Plastic handles are available at hardware stores. Use a plastic handle, as it is lighter than a metal one.

6.2. Procedures

6.2.1. Handle Reinforcement

When bolted to just Styrofoam, a hatch handle soon breaks out of the Styrofoam. To prevent this from occurring, the hatch requires reinforcement where the handle is bolted to it. Create the handle reinforcement as outlined below.

- √ Mark the center of the hatch, on both the top and bottom surfaces.
- √ Draw a one-inch by five-inch rectangle on the Styrofoam, centered and aligned with the hatch's sides.
- √ Draw this rectangle on the other face of the hatch, and aligned in the same direction.
- √ Cut two pieces of one-inch by five-inch rectangle of 1/16-inch thick plywood.
- √ Epoxy the plywood to the Styrofoam on the drawn outline.
- √ After the epoxy sets, determine the location of the handle's bolt holes.
- √ Drill two holes through the hatch and reinforcing plywood.
- √ Test fit the handle and screws to the hatch.

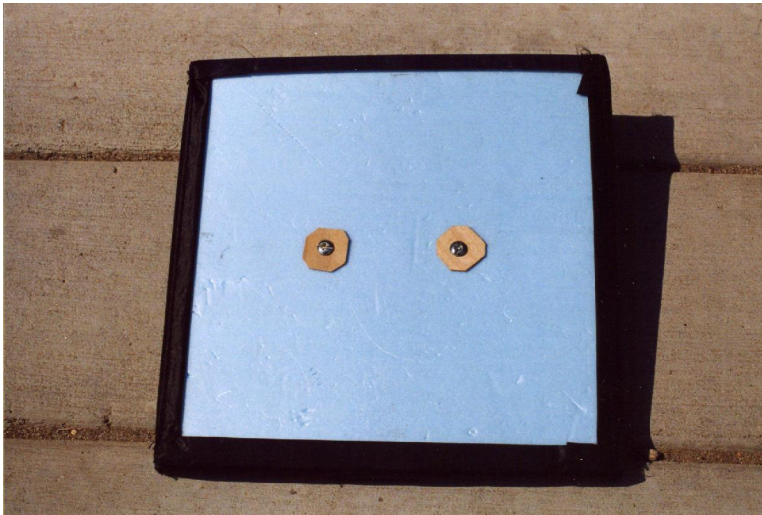

Handle Reinforcement -
Underside of hatch. Note the two
plywood "fender" washers.

6.2.2. Interior Face

If a GPS receiver is located inside the airframe, then do not cover the interior face of the hatch with aluminized Mylar, as it blocks signals from Navstar satellites. In this case, you may want to consider leaving the interior face of the hatch uncovered. Before covering the interior face, test the material for GPS compatibility by placing a couple of layers of the material over a GPS receiver and observing the number of satellite locks and their signal strengths. As long as the before and after measurements do not change significantly, the material is GPS safe. As mentioned earlier, a space blanket is not GPS safe. A single layer was observed by the Treasure Valley Near Space Program (TVNSP) to block Navstar signals while several inches of Styrofoam was not. Personally, I prefer to use either gold or silver colored wrapping plastic for my hatch interiors. Follow the steps below to make an interior lining.

- √ Select the lining material.
- √ Test for GPS compatibility.
- √ Cut a square of lining material several inches larger than the hatch in both dimensions.
- √ Lay the material out on a flat surface, with the outer face down.

- √ Place a border of double-stick tape on the hatch, located on its bottom face and near the edges of the hatch. Note: I have had trouble finding a good adhesive for gluing Mylar to Styrofoam, so I rely on tape.
- √ Carefully place the hatch centered on top of the material.
- √ With an Exacto knife, cut the lining material from the corners of the hatch to the edges of the material.
- √ Wrap the exposed edges of the lining material over the sides of the hatch.
- √ Tape the ends of the lining material to the hatch top.

6.2.3. Fabric Jacket

Next up, cutting and sewing spinnaker to cover the top and sides of the hatch. The completed spinnaker jacket must cover the top face, wrap around the sides, and part way across the bottom of the hatch. I cover about 1/2" of the inside bottom edge with spinnaker. I use the following procedures to make a hatch jacket.

- √ Select a spinnaker fabric to cover the hatch.
- √ Make a pattern for the jacket on poster board. Note: The pattern below is used on ten-inch by ten-inch hatches. If you decide to draw your own pattern, do not forget there's a seam allowance folded into the edges.
- √ Transfer the pattern onto the spinnaker with a colored pencil.
- √ Use a hot cutter to cut the fabric (or scissors if you don't have access to a hot cutter).
- √ Fold the spinnaker and crease the folds with a fingernail.
- √ Sew the raw edge of the hatch jacket over to prevent fraying.

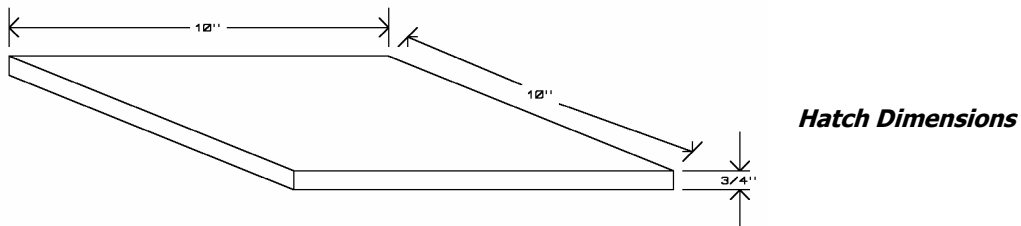

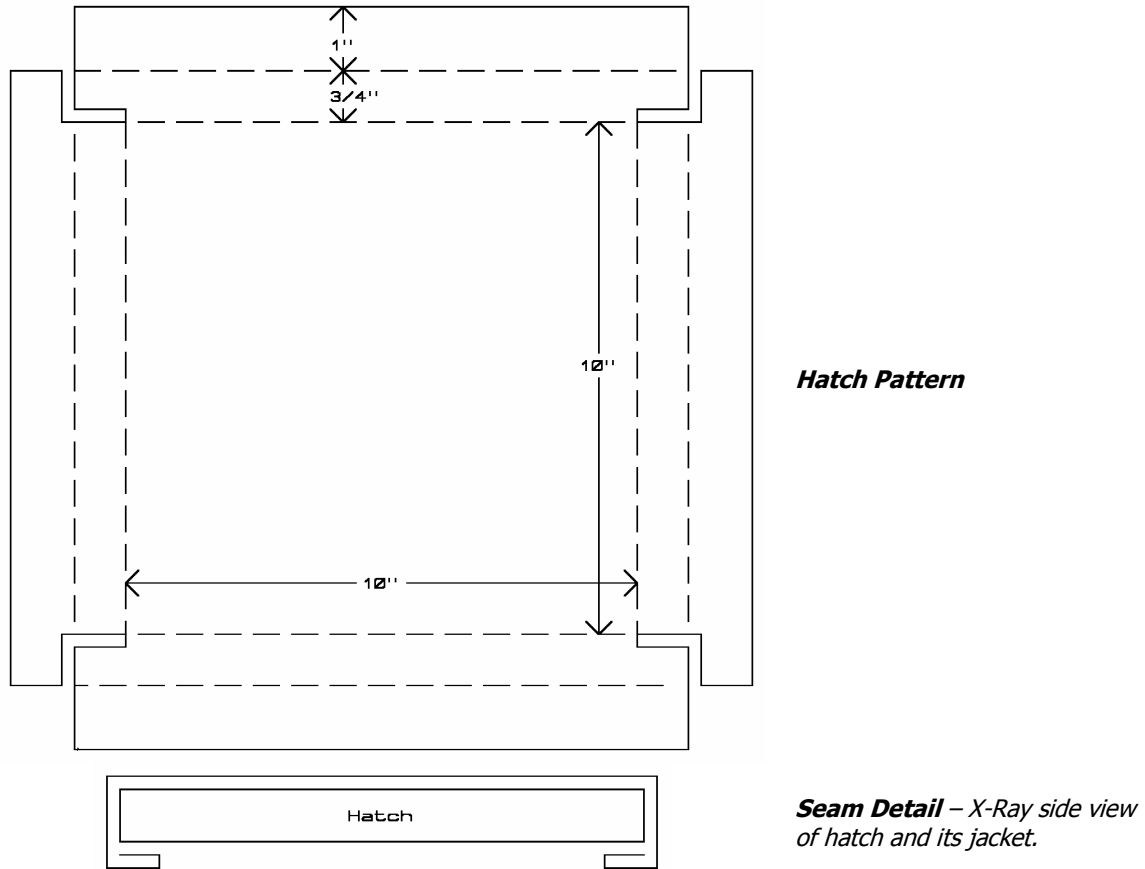

The hatch is secured to the airframe with four Velcro strips. The strips can be sewn to either the sides of the hatch or to the top, along the edges. A second option is to sew Velcro at both locations to add additional strength to the closure.

- ✓ Cut four (or eight) lengths of Velcro, two inches long. Note: Be sure to use the second half of the Velcro strips used to make the closures on the abrasion jacket.
- ✓ Find and mark the center of the edges of the hatch cover.
- ✓ Sew the Velcro strips to the hatch jacket, centered on the centering marks.

You may want to sew more Velcro strips to the jacket to secure experiments. If so, determine a location for them, and their length. Take into account the presence of the hatch handle when determining a location for the additional Velcro strips.

- ✓ Locate and mark the location for the additional Velcro.
- ✓ Cut Velcro to the desired length.
- ✓ Sew the Velcro to the hatch cover.
- ✓ Place the hatch jacket over the exposed face of the hatch.
- ✓ Cut or melt holes through the jacket for mounting the pull handle.
- ✓ Mount the handle to the hatch with the screws included in the handle.
- ✓ Neatly wrap the jacket around the hatch.
- ✓ Use masking tape to temporarily attach the jacket to the hatch.
- ✓ Hand sew the corners of the hatch covering together.
- ✓ Remove remaining masking tape.

- √ Test fit the hatch to the airframe. Note: The abrasion jacket Velcro closure straps should cover the Velcro patches on the hatch, securing the hatch to the rest of the airframe. The abrasion jacket Velcro closure straps should not interfere with any Velcro patches you may have sewn to the hatch jacket for lightweight, external experiments.



Completed Hatches – Ready to go.

6.2.4. Airframe Quality Assurance

Here's a list (by no means comprehensive) of inspection items for the airframe:

- √ Airframe is square.
- √ Airframe is rigid.
- √ Styrofoam tape is not peeling.
- √ Ports are cut to identical size, except for the control port.
- √ No fabric covers the port openings.
- √ No loose strings hang from the spinnaker or Velcro.
- √ Link loops can be pulled on hard without ripping seams.
- √ Velcro closures can be pulled on without ripping seams.
- √ Velcro closures do not interfere with additional Velcro patches.
- √ Airframe's name card can be removed from its clear plastic pocket.

7.0 Making Link Lines

The FAA allows us to fly the greatest amount of weight if we split the payload up (actually, you can fly heavier single payloads, but it adds a complication). So what does this mean? It means it is time to build your second airframe. The second airframe goes faster since you have experience building an airframe. A single sheet of Styrofoam lets you construct a fleet of near spacecraft.

7.1. Function of Link Lines

Near space modules are completed airframes filled with electronics. The module containing the telemetry equipment is the primary module while the supporting modules are the secondary modules. A near spacecraft is one or two modules (usually two) linked to perform a mission. Modules are linked together with link lines. Link lines attach the top corners of the bottom module to the bottom

corners of the top module. Using four link lines between modules keeps the modules level with respect to each other and also prevents a module from falling from near space should a single link line break during flight. The link lines described below are durable, reusable, and quick to link.

List of Materials

To make a set of link lines, you'll need the following items:

- A spool of 100 pound test Spectra kite line
- Eight #3 or larger barrel swivels*
- Eight inches of identically colored heat shrink tubing
- Scissors
- Heat gun or lighter

*** Do not use snap swivels, as they will open up during a flight, releasing the modules from each other.**

7.2. Procedure

There are two important notes about making link lines. First, make link lines from four identical lengths of Spectra kite line. I find twenty inch long link lines to be good, but you can cut them to whatever length you prefer. However, do not make them too long, or else you'll be making long electrical umbilicals later. Second, there may be times you'll need additional sets of link lines, each of a different length. In that case, make each set of four link lines with the same color heat shrink tubing and different length link lines with a different color of heat shrink tubing. This way launch crews are assured of identifying four identically long link lines by looking at their color.

- √ Cut four identical lengths of Spectra
- √ Melt the ends of the Spectra with a lighter to keep the lines from unraveling. Use just enough heat to seal the ends, but not to change their lengths significantly.
- √ Mark three inches from each end of a link line with a laundry marker.
- √ Cut eight pieces of one inch long heat shrink tubing.
- √ Slide two pieces of heat shrink tubing onto the link line.
- √ Slide two barrel swivels onto the link line.
- √ Center the loop of a swivel over a 3" mark on the link line and tie an overhand knot with the doubled-over string. Make sure to keep the laundry mark centered in the swivel loop while you tie the knot.
- √ Trim up the excess string from each knot. The excess string doesn't have to be very long, less than 1/2" will do.
- √ Melt the new ends of the nylon string, being careful not to damage the rest of the link line.
- √ or, use a drop of CA glue on the new ends of the nylon string.
- √ Slide a piece of heat shrink tubing over the knot and center it.
- √ Slide the second piece over the knot at the other end.
- √ Apply heat with a heat gun (or lighter) and shrink the tubing securely over each knot. Try not to excessively heat up link line material itself.
- Note: The heat shrink tubing helps keep the knot from pulling loose.
- √ Repeat the same process on the other three link lines.
- √ Give the completed link lines a good yank to verify they won't pull apart.



Two Link Lines - The colors of their heat shrink tubing indicates their lengths.

7.3. Using the Link Lines

- √ Identify the top and bottom modules of a near spacecraft.
- √ Position the modules on a launch tower in their flight configuration. Note: Using a launch tower ensures link lines are not twisted.
- √ Select four identical link lines.
- √ Slide the one ring of a barrel swivel into a split ring in the link loop.
- √ Slide the other end of the link line into the corresponding link loop of the other module.
- √ Inspect all the link lines after they are linked. Note: Be sure the Dacron loops are fully inserted into the split rings. Linking modules has a tendency to begin unlinking the Dacron from the split rings.

Your near spacecraft is just an empty box. It's now time to fill it with avionics. Read the next chapter on creating and programming near space trackers and the CC/PS flight computer.

Good to Know: A Short Introduction to Thermodynamics

The temperature of a body depends on three factors: the amount of energy contained within the body, the mass of the body, and the body's specific heat. The more thermal energy within a body, the greater its measured temperature when compared to the same body with less thermal energy. The more massive a body, the more energy is needed to raise its temperature to a given point. Finally, the specific heat of a material determines the amount of energy needed to raise the temperature of a unit mass of the material by one degree. Two bodies at the same temperature don't necessarily have the same amount of thermal energy within them. However, if brought in contact, the heat flow between the two bodies is equal in both directions. This is what happens when you use a thermometer to measure a temperature. Speaking of heat flow, let's look at how the ways thermal energy can flow between two or more bodies.

There are three methods to move heat energy between bodies: conduction, convection, and radiation. Conduction occurs between two bodies of different temperatures when they are brought into contact. There is a net flow of thermal energy from the warmer body into the cooler body. I say net, because there is some flow of thermal energy from the cooler body into the warmer body, which will further cool the colder body. The amount of thermal energy being transferred this direction is less than the

amount of thermal energy flowing into the cooler body. So regardless of their relative temperatures, there will always be heat flow in both directions, but the heat flow from the warmer body to the cooler body is greater in amount.

The second method of thermal energy flow between bodies is by convection. Convection is the movement of warmer material to regions containing cooler material. This is the method you observe when a pot of water boils. The hot water at the bottom of the pot rises to the top, displacing cooler water to the bottom where it warms up and repeats the cycle. Convection occurs in the lower layer of the atmosphere (troposphere), where the majority of our weather occurs, making this layer turbulent.

The final method by which thermal energy flows is radiation. Radiation occurs when a body emits radiation in the electromagnetic spectrum. Every body with a temperature greater than zero degrees Kelvin emits radiation. The higher the temperature of the body, the greater the amount of radiation it emits and the higher its peak frequency. As an example, a barely warm pot of water emits a little bit of radiation that peaks in the infrared portion of the spectrum. Meanwhile, very hot material falling into a black hole gives off vast amounts of energy that peaks in the X and gamma ray portion of the spectrum. Needless to say, it's safer to stand next to a pot of hot water than to the accretion disk of a black hole. Both warm and cool bodies in near contact emit radiation, but the warmer body emits more radiation, making the net emitted radiation from the warm body into the cool body. One high tech use of thermal radiation is that the radiation emitted by a warm body allows for a non-contact method for measuring temperature. These devices determine the temperature by measuring the peak-emitted frequency of radiation given off by a warm body.

Some Thermodynamic Concerns of Near Space

Some electronics are designed to be cooled by conduction with the surrounding air. Still warmer devices use a fan to move the air, putting the device in contact with even more air. In near space there's very little air, so you need to leave fan-cooled devices on the ground. Devices with heat sinks may need larger ones to cool properly.

MLI insulates both satellites and cryogenic equipment. MLI acts as a Dewar surrounding the equipment. The layers of reflective material prevent objects from changing temperature by reflecting thermal radiation emitted by the object back into the object. Scrim separating the layers of Mylar prevents a physical contact between the layers, thereby preventing conduction. Once in a vacuum, there is no air to move between the aluminized Mylar layers and carry away energy by convection. MLI has the benefit of being lightweight and is not fragile like glass.

Near Space Humor: Ten Signs that your First Near Space Mission is Not Going Well...

1. The Secret Service is at the launch site to observe.
2. You notice sparks and a trail of smoke leaving the near spacecraft just after you release it.
3. Mike Wallace and the 60 Minutes news crew are waiting for you at the recovery site.
4. Every one of the chase vehicles breaks down within the first 15 minutes of the chase.
5. The last you saw of the near spacecraft was a fiery streak falling from the sky.
6. You keep finding pieces of the near spacecraft on the ground during the chase.

7. You lost one of your balloon crews because he was tangled in the load line as the balloon was released.
8. One of the launch crews finds he is still holding onto the near spacecraft primary telemetry antenna after the balloon has been released.
9. The military police are waiting for you when you go to recover your near spacecraft that landed in Area 51.
10. The flight batteries die ten minutes into a flight which is predicted to reach 100,000 feet. You also remember that there is no message on the near spacecraft to tell finders who to call.

^A Styrofoam is a trademark of The Dow Chemical Company.

^B Spectra® is a registered trademark of Honeywell Performance Fibers.

^C Coroplast™ is a trademark of the Coroplast™ company.

^D Spinnaker cloth is also referred to as $\frac{3}{4}$ ounce ripstop nylon/polyester, meaning one square yard weighs $\frac{3}{4}$ of an ounce.

^E DACRON® is a registered trademark of INVISTA.

^F Velcro® is a registered trademark of Velcro Industries B.V.

^G Fray Stop Spray is manufactured by Sullivans USA (www.sullivans.net)

^H Cyanoacrylate adhesive, also known as Super Glue.

^I Mylar® is a registered trademark of DuPont Teijin Films.

^J Therm-a-Rest® is a registered trademark of Cascade Designs.